



USER INSTRUCTIONS

Serck Audco Double Isolation Plug Valve

FCD SRENIM0001-04-A4 – (08/14)

*Installation
Operation
Maintenance*

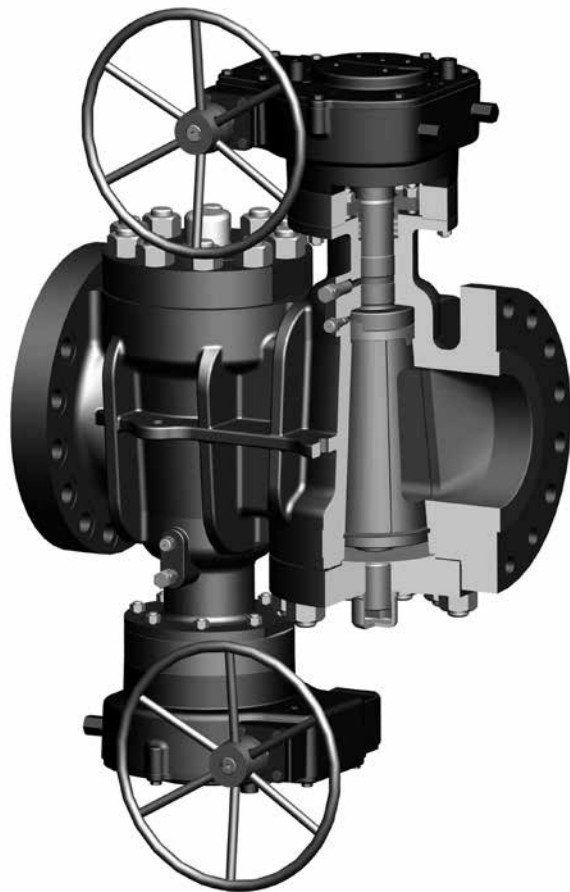

Experience In Motion



Contents

Storage Preservation	4
Valve Markings	5
Health & Safety	6
Preparation for Installation	8
Installation Instructions	9
Operation	10
Maintenance	11
Injection of Valve Sealant	11
Injection of Stem Packing Compound Adjustment	14
Adjustment of Plug Loading Screw	15
Rotating Plug Through 180 Degrees	16
Gear Operator Maintenance	16
Fastener Torque Requirements	16
Trouble Shooting Guide for DIPV Valves	17
Overhaul & Repair	18

1 STORAGE AND PRESERVATION

All valves are despatched in the open position and it is recommended that they are left in this position during storage. All protective packaging should remain in position until the valve is to be installed.

Valves should, where possible, be stored in a clean, dry environment.

In-Line Painting. DIPV valves are suitable for in-line painting. The following areas should be masked with rubberised masking materials or caulk, before shot blasting:

- Top of stem and gland area.
- Stem packing compound injector.
- Sealant fitting.
- Exposed end connections.
- Body-Cover joint.
- Gear box fittings, input shaft, and stop adjusters.
- Top works of bare stem valves that are to be fitted actuators or extensions.

It is also recommended that above areas be protected with a thick rust inhibitor or grease rather than be painted. This also ensures that no shot gets into the valve, that the wrench and hand wheel operators will fit easily, and the maintenance fittings are not damaged.

2 VALVE MARKINGS

Each valve has one of the following identification information plates attached to the body.

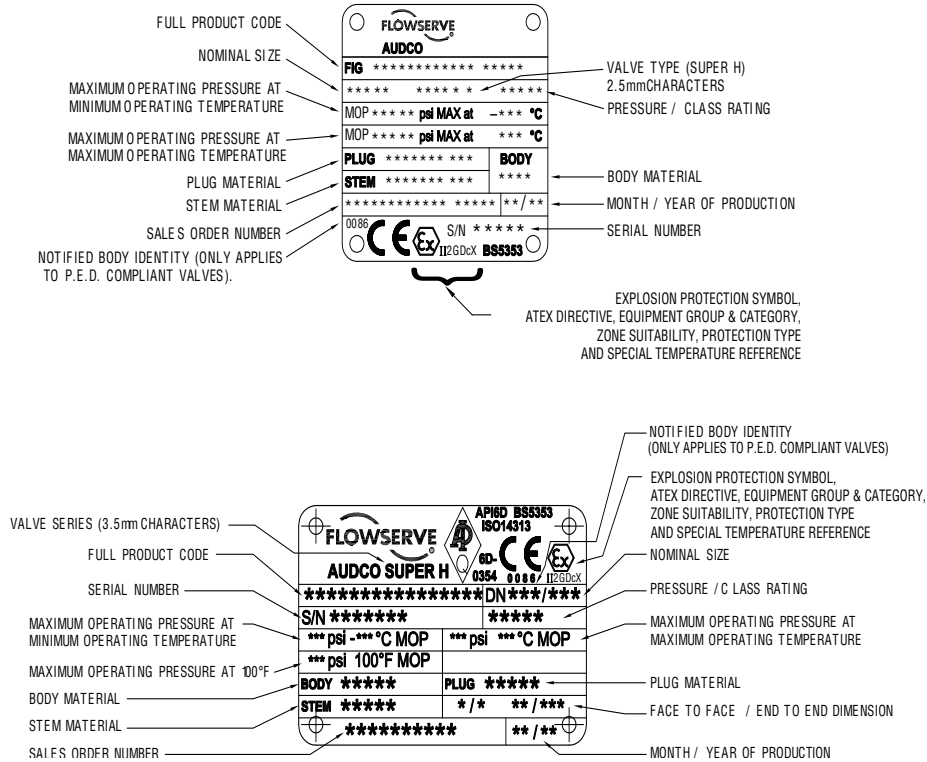

- 2.1 Pressure Equipment Directive: If the identity plate carries the Notified Body identity number '0086' beside the 'CE' mark, the product complies with the Pressure Equipment Directive 97/23/EC and the Pressure Equipment Regulations 1999 (SI 1999/2001). Without these numbers, and when used within the European community, the product is classified as 'SEP' (Sound Engineering Practice) and may only be used within the limitations defined in tables 6, 7, 8 & 9 of Schedule 3 of the Pressure Equipment Regulations.
- 2.2 ATEX Directive: If the identity plate carries the Explosion Protection Symbol and codes identifying the equipment group and category, the zone suitability and protection type beside the CE mark, the product complies with the ATEX Directive and The Equipment and Protective Systems for Use in Potentially Explosive Atmospheres Regulations 1996. Definition of identity plate marking above:
 'II' = Equipment Group; '2' = Equipment Category; 'G' = Gas Zone suitability (Zones 1 & 2);
 'D' = Dust Zone suitability (Zones 21 & 22); 'c' = type of protection i.e. constructional safety (BS EN 13463-5). 'X' = Special temperature reference.
- 2.3 Material traceability markings are hard marked on the body and cover.

3 HEALTH AND SAFETY

When installing or maintaining valves:

- a) Conduct a risk assessment and eliminate or reduce hazards to an acceptable level.
- b) Work in accordance with Safe Systems of Work.
- c) Observe all site Health and Safety Rules in particular Permit to Work and Hot Work procedures.
- d) Wear all necessary Personal Protective Equipment.
- e) Never remove the valve, maintain a joint, or loosen or remove any fastening or fitting unless the line has been fully drained and de-pressurised.
- f) Always operate the valve to the open position to ensure that no trapped pressure exists within the cavity.
- g) Never handle valves that have been used on harmful substances unless they have been completely decontaminated and certified safe to handle.
- h) Never use a valve on a duty which exceeds its prescribed operating parameters. Refer to Serck Audco Valves Technical Sales for further performance information.
- i) Never modify or alter valves unless the manufacturer has been consulted or recommends such changes.
- j) The valve wrenches are only designed for use in operating the valves and must not be used to carry them by. Failure to observe this warning may result in operator injury.
- k) Due to the large physical size and weight of some sizes of this product, always use correct lifting methods and equipment when installing, removing and maintaining the product:
Valves of 6" (150mm) nominal size and above, use the four lifting lugs on the body;
Valves of 4" (100mm) nominal size and below, use chains or slings wrapped around the body.
Do not attempt to lift the valve using the sealant fittings, gear unit, handwheel, actuator, wrench, or the tapped hole in the end of the stem.
Always ensure that the valve and operator assembly are correctly supported in their final operating location.
- l) Due to the variety of duties on which this product can be employed, it is the end users responsibility to ensure the compatibility of the media with the materials of construction of the product for each specific application (i.e. corrosion and erosion which may affect the integrity of the pressure containing envelope).
- m) Before equipment is installed in areas which may be subject to seismic activity or extreme climatic conditions consult Serck Audco Valves Technical Sales.

3 HEALTH AND SAFETY (cont.)

- n) End Flanges: The end flange design of this product has been verified by either:
ASME Boiler and Pressure Vessel Code Section VIII Division 1 calculation method;
Finite Element Analysis in accordance with ASME Boiler and Pressure Vessel Code Section VIII Division 2 - Alternative rules;
Experimental testing as defined in BS EN 12516-3, Valve Design Strength - Part 3 Experimental Method.
- Gaskets: The gaskets used in all methods are Spiral Wound to BS EN 1514-2 for PN rated Flanges and ASME B16.20 for Class rated flanges. These have Gasket Factors and Design Stresses of 2.5 and 10000 psi respectively for Carbon Steel gaskets, and 3.0 and 10000 psi respectively for Stainless Steel gaskets, as defined in the ASME Boiler and Pressure Vessel Code Section VIII Division 1.
- If gaskets are used with higher Gasket Factors and Design Stresses than those stated above, please consult Serck Audco Valves Technical sales.
- Bolting: End flanges for steel valves have been verified by the methods stated above, using bolt design stress values based on those for ASTM A193 B7, B7M, B8, B8M as defined in ASME Boiler and Pressure Vessel Code Section II - Materials - Part D - Properties.
- o) Lethal Service. In accordance with the design verification code (ASME Boiler and Pressure Vessel Code Section VIII Division 1) a casting quality factor of 1.0 is allowable for all products except those intended for 'lethal service'. All products for such service must have had non-destructive examination carried out in accordance with Appendix 7 of the code. Refer to Serck Audco Valves Technical sales.
- p) If the processes or environments that the products are used in are likely to cause temperatures (high or low) that may cause injury to personnel if touched, then adequate insulation/protection must be fitted. It is recommended that the insulation allows easy access for maintenance, to the sealant and stem packing compound fittings, and to the valve operator.
- q) If the equipment is to be used on unstable gas duty, ensure that the operational parameters as indicated on the product identification plate cannot be exceeded.
- r) This equipment should be protected by other devices to prevent over-pressurisation. (i.e. caused by external fire, etc).
- s) This equipment must be installed in a system that is designed to prevent excessive forces acting on the flanges, connections, etc.

4 PREPARATION FOR INSTALLATION

All protective packaging must be removed before installation.

It is recommended that additional sealant be injected prior to re-test and operation so as to ensure tight shut off, it is also recommended to re-energize the injectable stem packing compound.

Any excess sealant found around the plug port should be removed by using a scraper.

Clean end connections to remove any unwanted paint or rust inhibitor.

Significant problems can arise with any valve installed in an unclean pipeline.

Ensure that the pipeline has been flushed free of dirt, weld spatter, etc. before installation.

The working area should be clean and clear of any debris which could contaminate the valve.

The valve should be fully opened or fully closed during cleaning operations.

Water and inert gases such as carbon dioxide and nitrogen are unlikely to affect the sealant.

If solvents or steam cleaning are used, it is recommended that the valves are re-injected with sealant after completion of the cleaning operation.

5 INSTALLATION INSTRUCTIONS

- a) Serck Audco DIPV plug valves are bi-directional, and can be installed vertical (stem operating end at the top), horizontal or any angle in between. If the valve is installed in any other position, the operating torque will increase considerably, possibly resulting in seizure. The actuator may need supporting if it is not vertically above the valve. Ensure access to the sealant fitting, stem packing compound injector, plug loading screw, and any drain plugs. Ensure that the relief valve in the gear unit position indicator cannot discharge where it could cause personal injury.
- b) Installation of flanged valves should follow prevailing site standards. Where such standards do not exist the following should be used as a guideline.
- c) Flanged joints require compressive loading onto the gasket material as the normal line pressure forces tend to separate the joint. There should be no misalignment between the valve and mating faces.
- d) Pipework should have the correct gap to allow for the valve face to face length plus assembled gasket material width.
- e) Ensure the pipeline and flange faces are clean and free of any debris which may be detrimental to flange sealing.
- f) Bolting should be of the correct size, length, and material for the duty.
- g) Locate the valve between the pipe ends and slide in the gaskets. It may be necessary to lever the mating flanges gently apart to allow for easy fitting of the gasket. Care should be taken to prevent damage to the sealing surfaces. Correct lifting equipment must be used when handling valves for operator safety - see Section 3, paragraph k).
- h) Assemble all bolts and loosely tighten. Diametrically and evenly tighten the bolts to the correct torque required for the specific gasket material, per the gasket manufacturers recommendations.
- i) Screwed Ends - Pipe wrenches can be used to grip the valve body adjacent to the connection, while tightening it. Use of a thread sealant is recommended to ensure a pressure tight joint.
- j) Weld Ends - All welding should be performed by qualified welders using approved procedures. If good industry accepted practices are used (such as ASME IX), the heat from the welding will not affect the stem packing, or cause the sealant to decompose. Any post weld heat treatment (PWHT) must be restricted to the heat affected zone.
- k) Hub Ends - To be installed according to the hub end designers installation instructions.
- l) It is recommended that the valves are left in the open position during fitting.

5.1 COMMISSIONING TESTS

All valves are factory tested in accordance with valve industry standards API 6D, API 6A, API 598, or BS EN 12266-1, unless specified otherwise. If there is an operational need to test the valve at higher pressure, temperature or duration, consult Serck Audco Valves Technical Sales.

If water is used for testing, it is beneficial to dry out the valve internals by flushing the system with dry nitrogen or air, after the testing is completed.

6 OPERATION

6.1 USE

Serck Audco DIPV plug valves are Double Block & Bleed valves designed to give bubble tight shut off.

DIPV plug valves have a ¼ turn operation (i.e. they have a 90 degree rotation of the plug in operating from the fully open to the fully closed) and close in the clockwise direction when viewed from above the valve stem. It is possible to see when the valve is open or closed by the position of a groove in the top of the stem, this groove being in-line with the plug port.

Plug valves can be used for throttling for limited periods as typically done for applications such as vents, blow down, by-pass, equalization, kicker etc. If a DIPV is used for limited throttling, then it is suggested to use 1 plug for throttling and another one for isolation and proceed as follows: (1) open the isolating plug fully, (2) open the throttling plug slowly until media starts going through the valve (this should happen when the opening angle is 20-30°), (3) modulate the flow by opening further the plug as required, (4) when throttling is not required anymore continue to open until the valve is fully open. It is not good practice to leave a plug valve in the partially open (throttled) position for long periods as this may cause damage and seat life may be reduced.

Do not force valves that will not readily operate. Never stand downstream of a valve that is being opened to atmosphere. Valves that are installed where unauthorized personnel can interfere with them should normally have the wrench or handwheel removed, be locked with suitable locking devices, or be chained through the handwheel to prevent operation.

6.2 WRENCH OPERATION

Wrench operated valves have an arrow shaped position indicator fitted over the stem. The arrow points in the direction that the plug port is aligned. When the arrow points across the line of the pipe, the valve is closed. Similarly, if the wrench is removed the flats of the stem will also indicate the valve position. The indicator should not be removed as it also functions as the open and close stop by coming into contact with the stop pin adjacent to the stem.

To adjust the wrench tube position within the wrench head, remove the retaining screw, reposition the wrench tube, and then refit the retaining screw, and secure the wrench assembly to the stem by screwing the retaining screw into the hole in the top of the stem.

When operating the valve the use of excessive side loading on the wrench should be avoided. Serck Audco wrenches are sized so that the force to operate the valve should be 100 pounds maximum at the end of the wrench.

6.3 GEARBOX OPERATION

All worm gear boxes supplied by Serck Audco have visible arrow type position indicators on top of the gear housing. 'OPEN' and 'SHUT' positions are cast on top of the gear housing. The position indicator arrow points to these at the fully opened and closed positions.

Secure the gearbox handwheel to the gearbox input shaft by the pin, or by the key and the retaining screw. Ensure that the close direction indicator is visible on the end of the input shaft, and that the retaining screw is tightened down. It is also recommended that the gear unit stops be checked to ensure correct plug port alignment.

6.4 REMOTE OPERATION

Where automation of valves is required, Serck Audco can supply pneumatic, electric, hydraulic, or gas/hydraulic actuators to cover a wide range of operating torques. Operation will be in accordance with installation, operation and maintenance instructions for the relevant actuator.

Before pressurising the valve, ensure that all power sources are connected to the actuator, and that all of the actuator functions and accessories are working correctly.

7 MAINTENANCE

There are four maintenance operations that can be carried out on DIPV valves while in-line and on service. With these operations, except in cases where the plug becomes heavily eroded, corroded or damaged, DIPV valves can be fully maintained in-line for many years of trouble free service.

The four operations are:

- injection of valve sealant (required occasionally).
- injection of stem packing compound (emergency feature).
- adjustment of the plug loading screw (unlikely to ever be required).
- rotating the plug through 180 degrees (unlikely to ever be required).

7.1 INJECTION OF VALVE SEALANT

To maintain the bubble tight shut-off capabilities and to ensure smooth operation of the valve.

7.1.1 FREQUENCY OF SEALANT INJECTION

Service Conditions	Frequency of Sealant Injections
A. Infrequent operation, valve either fully opened or fully closed. Non abrasive liquids or gases.	Every 50 operations. minimum once per year.
B. Infrequent operation, valve either fully opened or fully closed. Abrasive liquids or gases.	Every 25 operations. minimum of 2 times per year.
C. Throttling services and abrasive services.	Every 10 operations, minimum of 4 times per year.

7.1.2 SEALANT INJECTION EQUIPMENT

DIPV valves have 'Giant Buttonhead' sealant fittings, unless the customer specifies special fittings such as sub-sea. To inject sealant, a high pressure sealant gun with a 'Giant Buttonhead' coupler is required. The gun should also have a pressure gauge reading to at least 10,000 psi. The three basic types that Serck Audco can supply are:

- a) Manual primed with screw feed - inexpensive guns for occasional use;
- b) Manual with hydraulic feed - recommended for servicing small groups of valves;
- c) Pneumatic, using bulk lubricant in 5 quart or larger cans - recommended for large valve installations, such as manifolds, gas processing plants, compressor stations, and refineries.

NOTE: Do not attempt to use low pressure lubricant guns (e.g. those used to grease wheel bearings).

7 MAINTENANCE (cont.)

7.1.3 VALVE SEALANTS AND LUBRICANTS

Only sealants recommended for TAPER plug valves should be used. Serck Audco supplies sealants for most services. If you already have a particular valve sealant in use at a facility, we will advise on the suitability for use in DIPV valves.

We strongly recommend against the following types of sealant:

- Sealant supplied by cylindrical/parallel plug valve manufacturers. These are of much higher viscosity than taper plug valves require and will substantially increase the valve torque.
- Commercially available lubricating grease such as bearing grease. These greases do not have the chemical resistance, lubricating and sealing properties required by taper plug valves.

7.1.4 INJECTING SEALANT

The sealant should be inserted using equipment suitable for plug valve seat sealant injection such as the 400-D sealant Gun or the 10-90 Trolley Gun or Hypregun or similar and is done by connecting the sealant injection equipment to the giant buttonhead fitting on the valve. Please refer to the manufacturers operating instructions for the operating and maintenance procedures of the sealant injection equipment. Sealant can be injected with the valve in-line and on pressure.

7.1.4.1 POSITION

If possible the valve should be fully opened or fully closed, to ensure that all four plug sealant grooves are connected to the sealant supply. If the valve is partially open, injection is less effective as only two of the grooves are connected to the supply.

7.1.4.2 SEALANT FITTING

Clean the 'Giant Buttonhead' fitting on the valve. In particular scrape off any paint build-up away from the small hole in the end of the fitting.

7.1.4.3 FILL THE GUN

Ensure the gun is filled and primed with the taper plug valve sealant.
Follow the gun manufacturers instructions to fill the gun.

7.1.4.4 ATTACH THE GUN

Slide the 'Giant Buttonhead' coupler on the end of the gun hose, over the valve's 'Giant Buttonhead' fitting, ensuring that the lip of the coupler fits into the groove in the fitting. If the gun has an isolating valve on the coupler or elsewhere, open this valve.

7 MAINTENANCE (cont.)

7.1.4.5 START PUMPING

Inject sealant either by pumping the handle on a manual gun, or connecting the air supply to the pneumatic gun. Monitor the pressure gauge during the sealant injection process. For sealant to flow onto the valve seats, enough sealant at sufficient pressure has first to be injected to overcome the line pressure, to fill any cavities in the sealant chamber and grooves, and to overcome the flow resistance through the valve sealant system.

Sealant is flowing onto the seats when the pressure gauge on the gun is significantly higher than the line pressure and then falls slowly. Note that on low pressure valves the pressure required to inject sealant may be significantly higher than the CWP.

With a valve that is regularly injected with sealant, the sealant pressure will quickly build up. A valve that has not been well maintained could require a significant amount of sealant to be injected before pressure builds up and sealant flows onto the seats.

See Section 8 - 'Trouble Shooting Guide' for potential injection problems.

7.1.4.6 DISCONNECT

After injection of sufficient sealant, relieve the internal pressure in the gun, and disconnect it from the 'Giant Buttonhead' fitting. CAUTION: The sealant gun should not be connected or disconnected while it still has internal pressure.

7.1.4.7 OPERATE THE VALVE

It is desirable but not essential, to operate the valve either partially or fully after injecting sealant, to help spread the sealant over the entire seating surfaces.

7 MAINTENANCE (cont.)

7.2 STEM PACKING COMPOUND ADJUSTMENT

DIPV plug valves have an emergency stem packing compound injector unit. In the unlikely event of a DIPV valve developing a stem leak, this fitting can be used to inject stem packing compound to re-seal the valve stem. This can be safely done with the valve under pressure.

CAUTION: Never unscrew the stem packing compound injector out of the DIPV valve body while the valve is under pressure.

On threaded stem DIPV valves, the injected stem packing compound is the primary seal. On the 'plain stem' design with a bolted top gland, it is an emergency feature to back up the main stem packing rings.

CAUTION: Never attempt to replace the stem packing rings in bolted gland DIPV, while the valve is under pressure. In some models a quad ring/carrier is located under the gland. Consult Serck Audco Valves Technical Sales for information on replacing these packing rings / quad rings and carriers.

Equipment Needed: Torque wrench and appropriate adaptor, Serck Audco stem packing compound & Anti Seize 2667.

7.2.1 CONFIRM SUSPECTED STEM LEAKAGE by one of several methods:

- Wrench operated valves - stem leak on a liquid service will be visible as liquid flowing out from where the stem protrudes from the body.
- Gas services - applying a detergent solution around the stem area will produce soap bubbles if the stem is leaking. A bad leak may be heard as a hissing noise from the stem area.
- Gear operated valves - the area where the stem protrudes from the body is hidden by the gear operator. Confirm stem leak by observing or applying a detergent solution around the relief valve in the gear operator indicator plate, and the gear operator to valve body mounting area.
- Portable electronic hydrocarbon detectors - some are sensitive enough to detect stem leaks by placing the probe adjacent to the stem.

7.2.2 THE STEM PACKING COMPOUND INJECTOR UNIT (SPCIU)

Consists of a hexagonal shaped (fitting) that is screwed into the valve body. Inside it is a check valve, and stem packing compound is forced through it with a hexagon socket or headed screw that threads into the end of the SPCIU.

Stem packing compound injectors are preloaded at the factory with sufficient Serck Audco stem packing compound to re-energise the stem seal on installation if required.

7.2.3 INJECTING STEM PACKING COMPOUND

already in the SPCIU, attach the allen key/hexagon socket to the torque wrench and locate on the hex. Socket/ headed screw in the centre of the, and rotate it clockwise until the recommended torque is reached. Normally only 1-3 turns will be possible. The maximum recommended torque is dependent on the size of the injecting hexagon screw or hexagon set screw. The torque values are

- 3/8" UNC (M10) torque required 20lb.ft (27Nm)
- 1/2" UNC (M12) torque required 24lb.ft (34Nm)
- 3/4" UNC (M20) torque required 45lb.ft (60Nm)

NOTE: It is important that the torque values are not exceeded to avoid damage or fracture to the stem packing fitting. It should be noted that it is difficult to inject stem packing using a winding tool; it is preferable to use a hexagon adaptor and a torque wrench. The injection screw must have a plain end. Operating the DIPV valve during the injection of stem packing compound can assist in resealing the valve stem.

7 MAINTENANCE (cont.)

7.2.4 RELOADING THE STEM PACKING COMPOUND INJECTOR

If the hexagon socket/headed screw bottoms out inside the SPCIU, and the stem is still leaking, then more stem packing compound needs to be loaded into the SPCIU. This is done by removing the hex socket/headed screw and putting a new piece of Serck Audco stem packing compound into the SPCIU and energizing it with the hexagon socket /headed screw. To the torque values listed above (section 7.2.3). Note: always apply Anti - seize to the stem packing before injection.

CAUTION: Never unscrew the stem packing compound injector out of the DIPV valve body while the valve is under pressure.

7.3 ADJUSTMENT OF THE PLUG LOADING SCREW

The plug loading screw is preset at the factory to position the tapered plug in optimum contact with the tapered body, i.e. the valve will seal off bubble tight and be readily operated. Most users of DIPV plug valves will never need to adjust this fitting, but occasionally it can be of benefit to adjust the plug into or out of the body seat.

Equipment Needed: Adjustable crescent wrench;
Hammer, and steel punch, (to loosen cap over plug loading screw.)

7.3.1 WHEN TO ADJUST THE PLUG LOADING SCREW

If a DIPV plug valve leaks across the seats even after injection of sufficient sealant onto the valve seats and is very easy to operate, then the plug is probably not in close enough contact with the body seat, and needs to be adjusted into the tapered body seat.

NOTE: Damaged metal seats can also produce these symptoms.

If a DIPV plug valve is very hard to operate, even after injection of sufficient sealant, then the plug could be pushed too far into the tapered body seat and needs adjusting out a little.

NOTE: Solids from the media (slurries, etc.) and from sealants with high levels of clay filler can also make the valve hard to turn.

7.3.2 ADJUSTING THE PLUG LOADING SCREW

This operation can be carried out with the valve on pressure.

7.3.2.1 EXPOSE THE PLUG LOADING SCREW

Identify the lock nut or cap that protects the plug loading screw. It is located in the centre of the valve cover. Remove the lock nut or cap by unscrewing it (counter-clockwise viewed from below the valve). On valves with cast caps there is a notch on the edge into which a steel punch can be inserted and tapped to loosen the cap.

7.3.2.2 ADJUSTING INTO THE TAPERED SEATS

To adjust the plug into the body seat, use an adjustable crescent wrench to tighten the plug loading screw until it becomes significantly harder to turn. It should take no more than one turn to tighten the plug loading screw, unless the it has already been slackened off. Once the plug loading screw feels tight enough, back it off by 1/8th of a turn.

CAUTION: Do not over-tighten the plug loading screw as this will jam the plug into the body seat.

7.3.2.3 ADJUSTING OUT OF THE TAPERED SEATS

To adjust a seized or hard to turn plug out of the body taper, slacken off the plug loading screw by 1/4 turn, then inject sealant into the valve, and this should ease the plug out sufficiently to make it operate smoothly.

CAUTION: Do not remove the plug loading screw from the valve cover.

7 MAINTENANCE (cont.)

7.3.2.4 AFTER ADJUSTING THE PLUG LOADING SCREW, refit the lock nut or protector cap, but do not over-tighten.

PLUG REVERSAL, AND GEAR UNITS

7.4 ROTATING PLUG THROUGH 180 DEGREES

Most DIPV plug valves are used where the flow is always in one direction. As DIPV are primarily downstream seating, the downstream seat takes the brunt of the wear and tear from normal usage. Typically the downstream face of the plug erodes first and causes leakage. There can be instances where the downstream plug seat is eroded while the upstream plug seat is still in good condition - by rotating the plug through 180 degrees, the good condition plug seat becomes the downstream seat and leakage will be stopped or substantially reduced, so extending the valve life.

CAUTION: Do not undertake this procedure with product flowing through the valve.

7.4.1 ROTATING THE PLUG ON WRENCH OPERATED DIPV VALVES

The 'V' shaped position indicator plate attached to the stem, stops the valve from being rotated more than 90 degrees. To rotate through 180 degrees, slide the snap-ring and position indicator plate off the valve stem and rotate the plug one half turn using the correct Serck Audco wrench. Refit the position indicator plate and snap-ring. Retest the valve seats as appropriate.

7.4.2 ROTATING THE PLUG ON GEAR OPERATED DIPV VALVES

This is a complicated procedure and should not be undertaken lightly.

First fully open the valve using the gear.

Then unbolt and remove the gear from the valve, noting how it was positioned.

Operate the gear back through 90 degrees and then fit it back on the valve with the stem and gear key-ways aligned.

Operate the valve 90 degrees using the gear and then remove the gear as before and operate it back through 90 degrees.

Refit the gear, aligning the key-ways, and bolt on the gear. The plug and gear have now been rotated through 180 degrees.

Retest the valve seats as appropriate.

7.5 GEAR OPERATOR MAINTENANCE

Gear operated DIPV valves are fitted with enclosed, water-tight, worm gear operators. Both single and double reduction units are used. Gear operators are manufactured by quality suppliers such as Mastergear.

All gears are lubricated with heavy bearing grease when assembled, and should not require subsequent lubrication. Gear operators not grease filled for life, will be fitted with a grease nipple.

If the gear operator input shaft gets bent or broken, we recommend that the entire gear operator be replaced as the internal bearings have probably also being damaged.

7.6 FASTENER TORQUE REQUIREMENTS

If any bolts/studs/nuts require tightening, the values must be obtained from SAV.

8 TROUBLE SHOOTING GUIDE FOR DIPV VALVES

PROBABLE CAUSES LISTED IN ORDER OF DESCENDING LIKELIHOOD

NOTE: 'SAV' is an abbreviation for Serck Audco Valves

	Trouble	Probable cause	Remedy
8.1	Hard to Operate	A. Lack of Sealant B. Too low temperature C. Dried out sealant D. Damaged gear operator E. Plug Overloaded into seat	A. Inject sealant (7.1) B. Inject low temperature sealant and/or insulate the valve C. Flush the valve with valve flush. Follow manufacturers instructions. Consult SAV for recommended sealant D. Consult SAV E. Reset Plug (7.3.2.3)
8.2	Will not fully open or close	A. Improper setting of gear operator stops	A. Reset stops for proper insulation
8.3	Leaks across seats	A. Lack of sealant B. Incorrect sealant C. Plug set incorrectly D. Damaged seats	A. Inject sealant (7.1) B. Consult SAV with service details C. Adjust plug loading screw (7.3.2.2) D. Rotate the plug 180 degrees (7.4) or consult SAV
8.4	Leaks at stem	A. Lack of stem packing compound	A. Inject stem packing compound (7.2)
8.5	Leaks at gear unit	A. Lack of stem packing compound	A. Inject stem packing compound (7.2)
8.6	Leaks at cover	A. Cover bolting loose - if this does not reseal cover the suspect: B. Damaged cover seal	A. Tighten cover bolts B. Remove from service, and consult SAV
8.7	Leaks through sealant fitting*	A. Ball check not seated B. Loose sealant check valve C. Damaged check valve	A. Inject sealant to clean and reseal check valve B. Remove from pressure and tighten check valve C. Remove from pressure and replace check valve
8.8	Leaks through valve body	A. Casting defect, internal corrosion or erosion	A. Remove from line and consult SAV

*NOTE: Injecting sealant into a valve that is leaking through the sealant fitting is normally a temporary fix, not a cure.

8.9 ACTUATED VALVES

Resolving operation problems on DIPV valves fitted with pneumatic, electric, hydraulic or gas/hydraulic actuators should be undertaken using the above recommendations in conjunction with the operator manufacturer instructions.

9 OVERHAUL AND REPAIR

DIPV VALVE OVERHAUL AND REPAIR

If by following the maintenance instructions in Section 7 and the Trouble Shooting Guide, Section 8, you are unable to get the DIPV valve to operate and seal correctly, then please contact Serck Audco Valves or our local representative for further assistance.





Serck Audco Valves
a division of Flowserve GB Ltd
Burrell Road, Haywards Heath
West Sussex RH16 1TL
United Kingdom
Telephone: +44 (0)1444 314560
Telefax: +44 (0)1444 314561
Email: savukinfo@flowserve.com

FCD SRENIM0001-04-A4 08/14 Printed in USA.

To find your local Flowserve representative
or for more information about Flowserve Corporation, visit
www.flowserve.com.

Flowserve Corporation has established industry leadership in the design and manufacture of its products. When properly selected, this Flowserve product is designed to perform its intended function safely during its useful life. However, the purchaser or user of Flowserve products should be aware that Flowserve products might be used in numerous applications under a wide variety of industrial service conditions. Although Flowserve can (and often does) provide general guidelines, it cannot provide specific data and warnings for all possible applications. The purchaser/user must therefore assume the ultimate responsibility for the proper sizing and selection, installation, operation, and maintenance of Flowserve products. The purchaser/user should read and understand the Installation Operation Maintenance (IOM) instructions included with the product, and train its employees and contractors in the safe use of Flowserve products in connection with the specific application.

While the information and specifications contained in this literature are believed to be accurate, they are supplied for informative purposes only and should not be considered certified or as a guarantee of satisfactory results by reliance thereon. Nothing contained herein is to be construed as a warranty or guarantee, express or implied, regarding any matter with respect to this product. Because Flowserve is continually improving and upgrading its product design, the specifications, dimensions and information contained herein are subject to change without notice. Should any question arise concerning these provisions, the purchaser/user should contact Flowserve Corporation at any one of its worldwide operations or offices.

© 2014 Flowserve Corporation, Irving, Texas, USA. Flowserve is a registered trademark of Flowserve Corporation.