

LINED BALL VALVES



VALVE SOLUTION
for Corrosive Applications

AUDCO ITALIANA
Your Valve Specialist

AUDCO ITALIANA srl
Headquarter and plant
Via Carlo Dell'Acqua, 1 | 20027 Rescaldina (MI) - Italy
Tel. +39.0331.1561323 | Fax +39.0331.1561327
info@audco.it | www.audco.it

BALL VALVES - FOR CORROSIVE APPLICATIONS

PFA LINED BALL VALVE SIDE SPLIT - FULL PORT LEVER OPERATED - ANSI

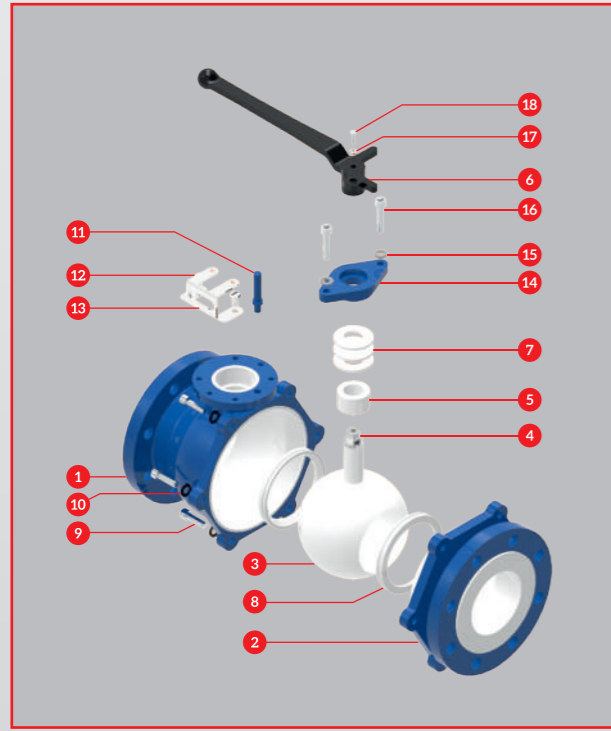

PART NO.	DESCRIPTION	MATERIAL OF CONSTRUCTION	QTY.
1	Body	ASTM A 216 GR. WCB + PFA LINED	1
2	Side Piece	ASTM A 216 GR. WCB + PFA LINED	1
3	Ball	CF8 INSTERTED PFA LINED	1
4	Stem Integral To Ball	CF8 + PFA LINED	1
5	Bush	PTFE	1
6	Handle	CS EPOXY PAINTED	1
7	Chevron	PTFE	3-6
8	Seat	PTFE	2
9	Allen Bolt For Body	ASTMA A 193 GR.B7	4-8
10	Allen Bolt Washer	STEEL	4-8
11	Stopper Pin	MILD STEEL	1
12	LOTO Clamp Bolts	SS 304	2
13	LOTO Clamo	SS 304	1
14	Gland Cover	ASTM A 351 GR. CF8	1
15	Plain Washer For Gland Cover	SS 304	2
16	Allen Bolt for Gland Cover	SS 304	2
17	Plain Washer For Handle	SS 304	1
18	Hex Bolt For Handle	SS 304	1

SECTIONAL VIEW

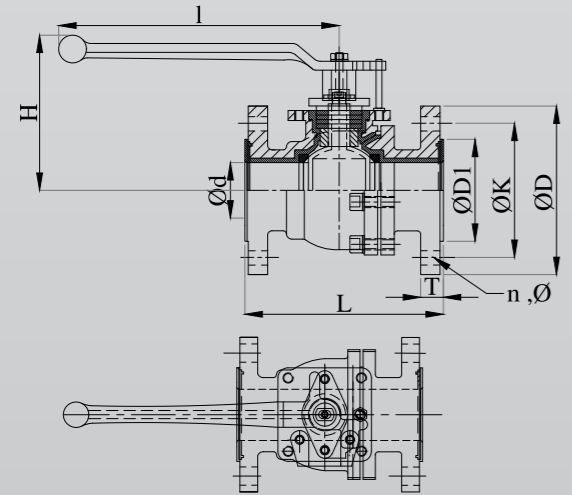

DIMENSIONS

SIZE	Ød ± 0.04		L ± 0.12		ØD ± 0.04		ØD1 ± 0.04		T+0.11/-0.00		H (Approx)		ØK ± 0.062		n	Ø ± 0.02		l ± 0.08	
	INCH	MM	INCH	MM	INCH	MM	INCH	MM	INCH	MM	INCH	MM	INCH	MM		INCH	MM	INCH	MM
0.5"	0.511	13	5.118	130	3.503	89	1.377	35	0.551	14	4.409	112	2.362	60	04	0.629	16	7.007	178
0.75	0.787	20	5.905	150	3.858	98	1.692	43	0.551	14	4.763	121	2.755	70	04	0.629	16	7.007	178
1"	0.987	25	5.000	127	4.251	108	2.007	51	0.669	17	4.763	121	3.110	79	04	0.629	16	7.007	178
1.5"	1.574	40	6.496	165	5.000	127	2.874	73	0.748	19	5.354	136	3.858	98	04	0.629	16	10.000	254
2"	1.968	50	7.007	178	5.984	152	3.622	92	0.807	20.5	5.472	139	4.763	12	04	0.748	19	10.000	254
2.5"	2.559	65	7.480	190	7.007	178	4.133	105	0.885	23	6.692	168	5.511	140	04	0.748	19	12.007	305
3"	2.952	75	7.992	203	7.519	191	5.00	127	0.984	25	6.968	177	5.984	152	04	0.748	19	12.007	305
4"	3.937	100	9.015	229	9.015	229	6.181	157	0.984	25	8.110	206	7.519	191	08	0.748	19	12.007	305

GEAR OPERATED

SIZE	Ød ± 0.04		L ± 0.12		ØD ± 0.04		ØD1 ± 0.04		T+0.11/-0.00		H (Approx)		ØK ± 0.062		n	Ø ± 0.02	
	INCH	MM	INCH	MM	INCH	MM	INCH	MM	INCH	MM	INCH	MM	INCH	MM		INCH	MM
6"	5.905	150	10.511	267	11.023	280	8.503	216	1.102	28	16.141	410	9.488	241	08	0.866	22

All Dimensions are in Inches & mm unless otherwise specified. Tolerances are given in Inches.
 • End to End Dimensions are as per DIN EN 558 - 1
 * Gear Operated

PFA LINED BALL VALVE SIDE SPLIT - FULL PORT LEVER OPERATED - DIN

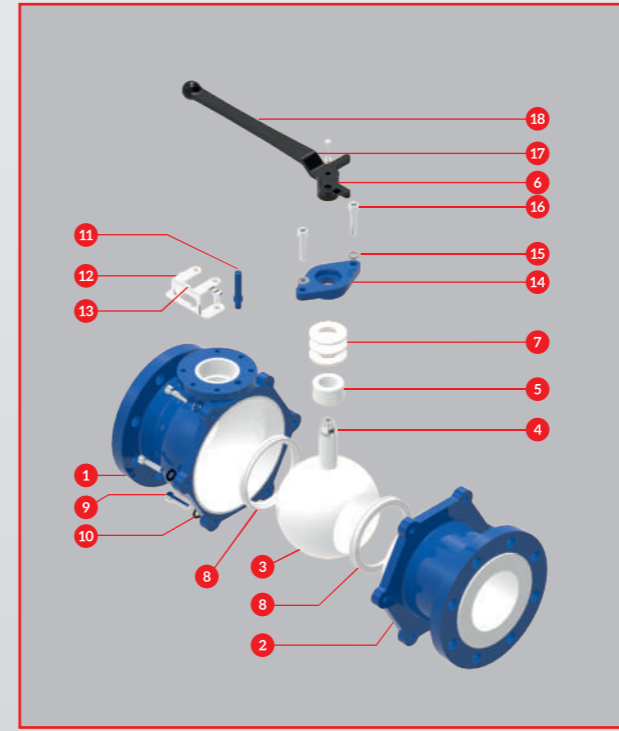

PART NO.	DESCRIPTION	MATERIAL OF CONSTRUCTION	QTY.
1	Body	ASTM A 216 GR. WCB + PFA LINED	1
2	Side Piece	ASTM A 216 GR. WCB + PFA LINED	1
3	Ball	CF8 INSTERTED PFA LINED	1
4	Stem Integral To Ball	CF8 + PFA LINED	1
5	Bush	PTFE	1
6	Handle	CS EPOXY PAINTED	1
7	Chevron	PTFE	3-6
8	Seat	PTFE	2
9	Allen Bolt For Body	ASTMA A 193 GR.B7	4-8
10	Allen Bolt Washer	HT STEEL	4-8
11	Stopper Pin	STEEL	1
12	LOTO Clamp Bolts	SS 304	2
13	1070 Clamp	SS 304	1
14	Gland Cover	ASTM A 351 GR. CF8	1
15	Spring Washer For Gland Cover	B7 / \$S 304 / SS 316 2	-
16	Allen Bolt for Gland Cover	B7 /\$S 304 /\$S 316 2	-
17	Plain Washer For Handle	SS 304	1
18	Hex Bolt For Handle	SS 304	1

SECTIONAL VIEW

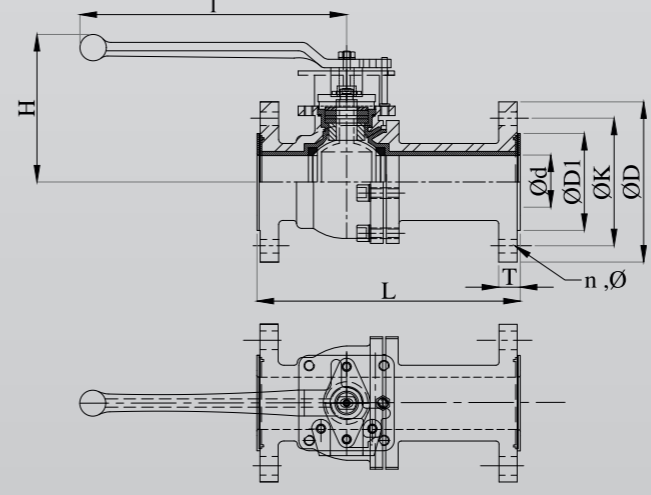

DIMENSIONS

SIZE	Ød ± 0.04		L ± 0.12		ØD ± 0.04		ØD1 ± 0.04		T+0.11/-0.00		H (Approx)		ØK ± 0.062		n	Ø ± 0.02		l ± 0.08	
	INCH	MM	INCH	MM	INCH	MM	INCH	MM	INCH	MM	INCH	MM	INCH	MM		INCH	MM	INCH	MM
0.5"	0.511	13	5.118	130	3.740	95	1.377	35	0.551	14	4.409	112	2.559	65	04	0.551	14	7.007	178
0.75	0.787	20	5.905	150	4.133	105	1.692	43	0.551	14	4.763	121	2.952	75	04	0.551	14	7.00	178
1"	0.9841	25	6.299	160	4.527	115	2.007	51	0.669	17	4.763	121	3.346	85	04	0.551	14	7.007	178
1.5"	1.574	40	7.874	200	5.905	150	2.874	73	0.748	19	5.354	136	4.330	110	04	0.708	18	10.000	254
2"	1.968	50	9.055	230	6.496	165	3.622	92	0.807	20.5	5.472	139	4.921	125	04	0.708	18	10.000	254
2.5"	2.559	65	11.417	290	7.283	185	4.133	105	0.885	22.5	6.692	170	5.708	145	04	0.708	18	12.007	305
3"	2.952	75	12.204	310	7.874	200	5.00	127	0.984	25	6.968	177	6.299	160	08	0.708	18	12.007	305
4"	3.937	100	13.779	350	8.661	220	6.181	157	0.984	25	8.110	206	7.086	180	08	0.708	18	12.007	305

GEAR OPERATED

SIZE	Ød ± 0.04		L ± 0.12		ØD ± 0.04		ØD1 ± 0.04		T+0.11/-0.00		H (Approx)		ØK ± 0.062		n	Ø ± 0.02	
	INCH	MM	INCH	MM	INCH	MM	INCH	MM	INCH	MM	INCH	MM	INCH	MM		INCH	MM
6"	5.905	150	10.511	267	11.023	280	8.503	216	1.102	28	16.141	410	9.488	241	08	0.866	22

All Dimensions are in Inches & mm unless otherwise specified. Tolerances are given in Inches.
 • End to End Dimensions are as per DIN EN 558 - 1
 * Gear Operated

PFA LINED BALL VALVE CENTRAL SPLIT - FULL PORT LEVER OPERATED

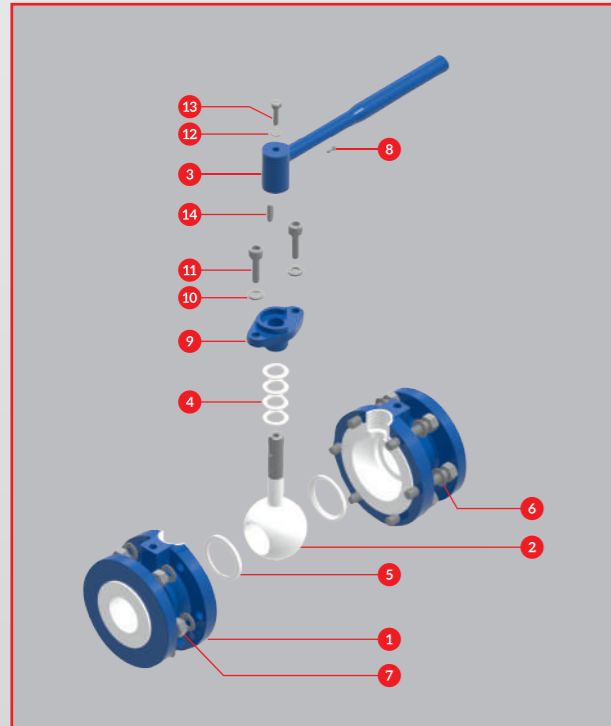

PART NO.	DESCRIPTION	MATERIAL OF CONSTRUCTION	QTY.
1	Body	ASTM A 216 GR. WCB + PFA LINED	2
2	Ball With Integral Stem	CF8 INSERTED PFA LINED	1
3	Handle	CS EPOXY PAINTED	1
4	Chevron	PTFE	4-6
5	Seat	PTFE	2
6	Studs	ASTM A 193 GR. B7	4-10
7	Nuts	ASTM A 193 GR. 2H	8-20
8	Stopper Pin	ALEN BOLT HT 10.9	1
9	Gland Cover	ASTMA 216 GR. WCB	1
10	Plain Washer For Gland Cover	MS GALVANIZED	2
11	Allen Bolt for Gland Cover	HT GRADE 10.9	2
12	Plain Washer for Handle	STEEL GALVANIZED	1
13	Hex Bolt For Handle	HT10.9	1
14	Key For Handle	HT STEEL	1

SECTIONAL VIEW

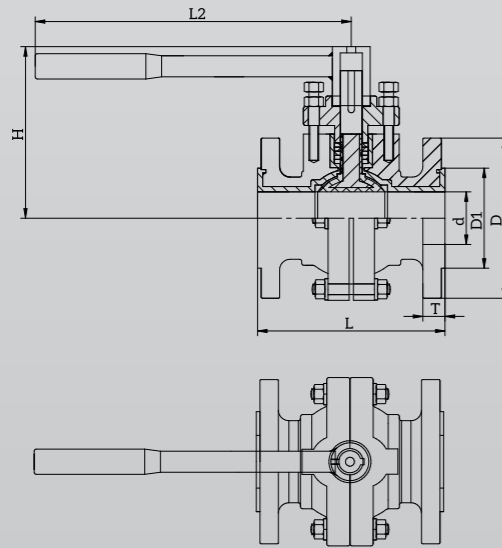

DIMENSIONS

SIZE	L ± .12		d ± .04		D ± 0.04		D1 ± 0.08		L2 ± 0.11		H (Approx)		T+0.11/-0.00		PCD ± 0.062		n	Ø ± 0.02	
	INCH	MM	INCH	MM	INCH	MM	INCH	MM	INCH	MM	INCH	MM	INCH	MM	INCH	MM		INCH	MM
0.5"	4.25	108	0.51	13	3.50	89	1.38	35	7.87	200	4.33	110	0.55	14	2.36	60	04	5/8	16
0.75"	4.65	118	0.75	19	3.85	98	1.69	43	7.87	200	4.92	125	0.55	14	2.75	70	04	5/8	16
1"	5.00	127	0.94	25	4.25	108	2.00	51	7.87	200	4.92	125	0.63	16	3.10	79	04	5/8	16
1.5"	6.49	165	1.57	40	5.00	127	2.87	73	9.84	250	5.31	135	0.74	19	3.85	98	04	5/8	16
2"	7.00	178	1.96	50	5.98	152	3.62	92	12.20	310	6.30	160	0.80	20.50	4.76	121	04	3/4	19
2.5"	7.48	190	2.55	65	7.00	178	4.13	105	12.79	325	6.49	165	0.90	23	5.51	140	04	3/4	19
3"	7.99	203	2.95	75	7.51	191	5.00	127	12.79	350	6.89	175	0.98	25	5.98	152	04	3/4	19
4"	9.00	229	3.93	100	9.00	229	6.18	157	13.77	350	7.87	200	0.98	25	7.51	191	08	3/4	19
6"	10.50	267	5.90	150	11.00	280	8.50	216	19.68	500	12.20	310	1.10	28	9.48	241	08	7/8	22

All Dimensions are in Inches & mm unless otherwise specified. Tolerances are given in Inches.

PFA LINED BALL VALVE CENTRAL SPLIT - FULL PORT GEAR OPERATED

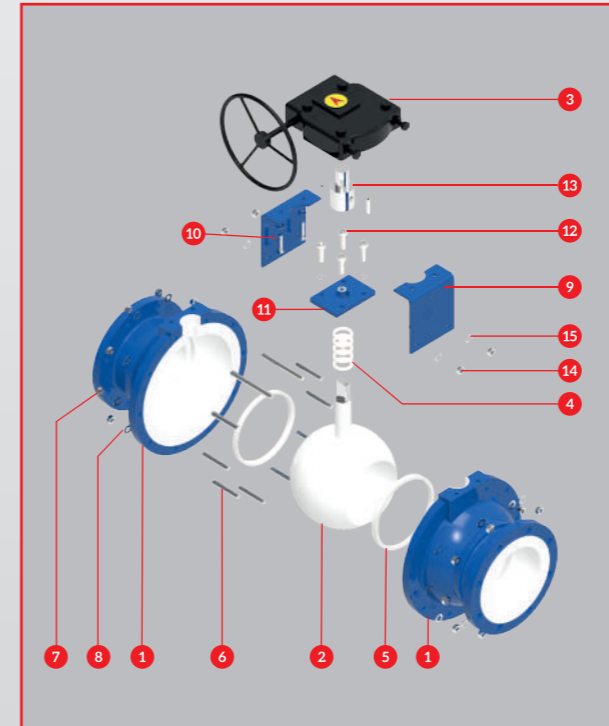

PART NO.	DESCRIPTION	MATERIAL OF CONSTRUCTION	QTY.
1	Body	ASTM A 216 GR. WCB + PFA LINED	2
2	Ball With Integral Stem	CF8 INSERTED PFA LINED	1
3	Gear Box	CAST IRON EPOXY PAINTED	1
4	Chevron	PTFE	5
5	Seat	PTFE	2
6	Studs	ASTM A 193 GR. B7	12-16
7	Nuts	ASTM A 193 GR. 2H	24-32
8	Washers For Studs	STEEL	24-32
9	Gear Box Mounting Clamps	MS GALVANIZED / SS	2
10	Gear Box Clamp Allen Bolts	HT 10.9	4
11	Gland Cover	ASTM A 216 GR. WCB	1
12	Allen Bolt For Glad Cover	HT 10.9	4
13	Coupler Spindle / Gearbox	SS 304	1
14	Clamp Mounting Nuts	HT	4
15	Clamp Mounting Washers	HT	4

SECTIONAL VIEW

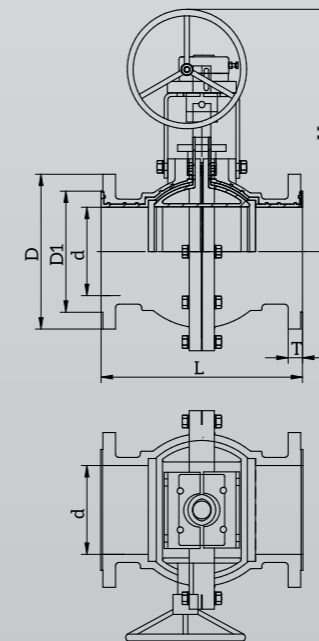

DIMENSIONS

SIZE	L ± .12		d ± .04		D ± 0.04		D1 ± 0.08		H (Approx)		T+0.11/-0.00		PCD ± 0.062		n	Ø ± 0.02	
	INCH	MM	INCH	MM	INCH	MM	INCH	MM	INCH	MM	INCH	MM	INCH	MM		INCH	MM
8"	17.99	457	7.87	200	13.50	343	10.62	270	22.63	575	1.18	30	11.73	298	08	7/8	22
10"	20.98	533	9.84	250	15.98	406	12.75	324	24.60	625	1.29	33	14.25	362	12	1	25
12"	24.01	610	11.81	300	19.09	485	15.00	381	27.95	710	1.37	35	17.00	432	12	1	25

All Dimensions are in Inches & mm unless otherwise specified. Tolerances are given in Inches.

PFA LINED BALL VALVE

SIDE SPLIT - REDUCE PORT LEVER OPERATED

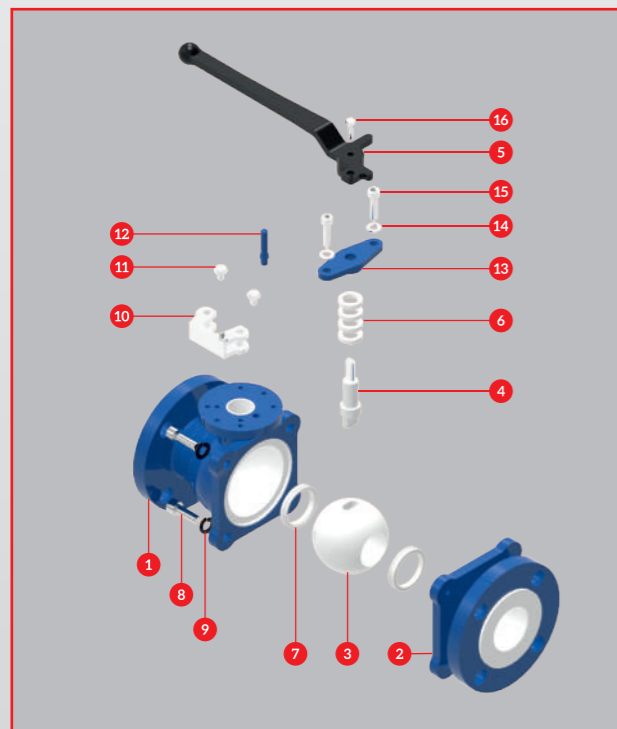

PART NO.	DESCRIPTION	MATERIAL OF CONSTRUCTION	QTY.
1	Body	ASTM A 216 GR. WCB + PFA LINED	1
2	Side Piece	ASTM A 216 GR. WCB + PFA LINED	1
3	Ball	CF8 INSERTED PFA LINED	1
4	Spindle	CF8 INSERTED PFA LINED	1
5	Handle	CS EPOXY PAINTED	1
6	Chevron	PTFE	4-5
7	Seat	PTFE	2
8	Allen Bolt For Body	ASTM A 193 GR. B7	4
9	Plain Washer	HT STEEL	4
10	Locking Clamp	SS 304	1
11	Hex Bolt For Locking Clamp	SS 304	2
12	Stopper Pin	STEEL	1
13	Gland Cover	ASTM A 351 GR. CF8	1
14	Plain Washer for Gland Cover	SS 304	2
15	Allen Bolt for Gland Cover	SS 304	2
16	Hex Bolt For Handle	SS 304	1

SECTIONAL VIEW

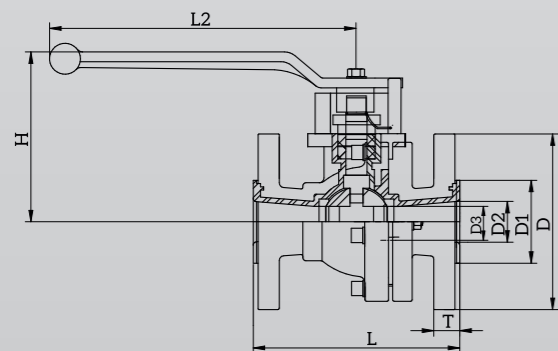

DIMENSIONS

SIZE	L ± 0.12		D2 ± 0.04		D1 ± 0.08		D ± 0.04		L2 ± 0.11		H (Approx)		T+0.11/-0.00		PCD ± 0.062		n	Ø ± 0.02	
	INCH	MM	INCH	MM	INCH	MM	INCH	MM	INCH	MM	INCH	MM	INCH	MM	INCH	MM		INCH	MM
1"	5.00	127	0.94	25	2.00	51	4.25	108	7.00	178	4.76	121	0.67	17	3.10	79	04	5/8	16
1.5"	6.49	165	1.57	40	2.87	73	5.00	127	10.00	254	5.35	136	0.74	18.8	3.85	98	04	5/8	16
2"	7.00	178	1.96	50	3.62	92	5.98	152	10.00	254	5.47	139	0.81	20.5	4.76	121	04	3/4	19
3"	7.99	203	2.95	75	5.00	127	7.51	191	12.00	305	6.96	177	0.98	24.90	5.98	152	04	3/4	19
4"	9.00	229	3.93	100	6.18	157	9.00	229	12.00	305	8.11	206	0.98	24.90	7.51	191	08	3/4	19

All Dimensions are in Inches & mm unless otherwise specified. Tolerances are given in Inches.

BALL VALVE FEATURES

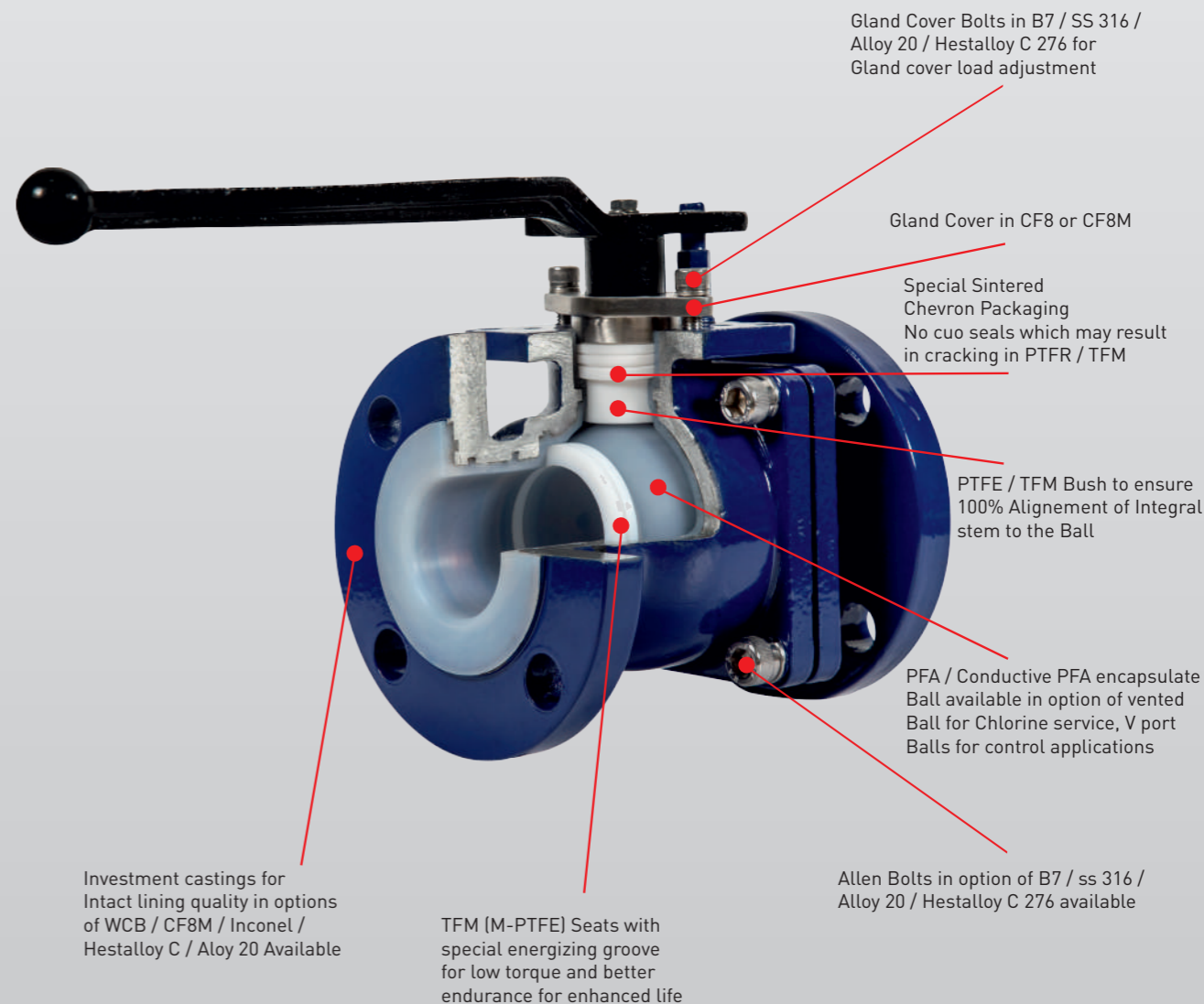

PRODUCT DESIGN AND TESTS PERFORMED

DESIGN PARAMETERS	STANDARD
DESIGN STD	BS EN 17292
SHELL DESIGN	ANSI B 16.34
FLANGE CONNECTION RATING	ANSI B 16.5, 150#/ DIN PN 10 / JIS
TESTING STANDARD	API 598 / BS EN 122661
CONNECTION	FLANGED, RF

TEST PERFORMED	API 598	API 598
SIZES	0.5" TO 4"	6" TO 12"
HIGH PR. SHELL TEST HYDRO	420 PSI	225 PSI
HIGH PR. SEAT TEST HIDRO	270 PSI	165 PSI
KOW PR. SEAT PNEUMATIC	105 PSI	75 PSI

SPARK TEST	KVDC
SPARK TEST	20 KVDC

VALVE CV & TORQUE VALUES

SIZE	Cv FULL PORT	Cv RED. PORT	TORQUE NM FULL PORT	TORQUE NM REDUCED PORT	TORQUE INCH-LBS FULL PORT	TORQUE INCH-LBS REDUCED PORT
0.5"	15	-	10	-	88	-
0.75"	25	-	12	-	106	-
1"	50	39	12	10	106	88
1.5"	185	50	20	18	177	159
2"	320	191	25	22	221	195
3"	805	330	40	35	354	310
4"	1600	790	65	50	575	443
6"	4500	-	180	-	1593	-
8"	8300	-	280	-	2478	-
10"	11725	-	350	-	3098	-
12"	18100	-	500	-	4425	-

TYPE	SIZE	STANDARD FOR END TO END DIM
FULL PORT SIDE SPLIT	1" - 6"	ANSI B 16.1 SHORT PATTERN
FULL PORT CENTRESPLIT	8" - 12"	ANSI B 16.1 LONG PATTERN
FULL PORT SIDESPLIT	1/2" & 3/4"	DIN EN 558 SERIES - 1
FULL PORT SIDE SPLIT	1/2" - 6"	DIN EN 558 SERIES- 1

VALVE CODE USED

TYPE OF VALVE	CODE
FULL PORT SIDE SPLIT BALL VALVE	BVFP
FULL PORT CENTRE SPLIT BALL VALVE	BVFP
REDUCED PORT SIDE SPLIT BALL VALVE	BVRP

BODY CASTING	CODE
ASTM A 216 GR WCB	C1
ASTM A 351 GR. CF 8	C2
ASTM A 351 GR. CF8M	C3

TRIM INSERTS	CODE
ASTMA A 351 GR. CF8	T2
ASTM A 351 GR. CF8M	T3
ASTM A 890 GR. 4A(CD3MN)	T5

LINING MATERIAL	CODE
PA	L1
FEP	L2
PVDF	L3
ETFE	L4
PPH	L6
ANTISTATIC PFA	L7

BODY BOLTS	CODE
SS 304	F2
SS 316	F3
HIGH TENSILE	F4
ASTM A 193 GR. B7	F5

VALVE CODE USED

LOCKING	CODE
PROVIDED	Y
NOT PROVIDED	N

SIZE											
0.5"	0.75"	1"	1.5"	2"	2.5"	3"	4"	6"	8"	10"	12"
CODE											
0H	75	01	1H	02	2H	03	04	06	08	10	12

HOW TO READ CODE

CODE	BVFPCT13L1F5LY02	
VALVE TYPE	BALL VALVE FULL PORT	BVFP
BODY CASTING	ASTM A 216 GR. WCB	C1
TRIM INSERT	ASTM A 351 GR. CF8M	T3
LINING MATERIAL	PFA	L1
FASTNERS	ASTM A193 GR. B7	F5
OPERATION	LEVER	L
LOCKING ARRANGMENT	PROVIDED	Y
VALVE SIZE	2"	02

WEIGHT CHART / VALVE

SIZE	WT. IN KGS CENTRE SPLIT FULL PORT	WT. IN LBS CENTRE SPLIT FULL PORT	WT. IN KGS SIDE SPLIT FULL PORT (ANSI)	WT. IN LBS SIDE SPLIT FULL PORT (ANSI)	WT. IN KGS SIDE SPLIT FULL PORT (DIN)	WT. IN LBS SIDE SPLIT FULL PORT (DIN)	WT. IN KGS SIDE SPLIT REDUCED PORT	WT. IN LBS SIDE SPLIT REDUCED PORT
0.5"	3	7	3.00	7	3.00	7	-	-
0.75"	3.8	8.5	3.95	9	3.95	9	-	-
1"	4.5	10	4.50	10	4.90	11	4.2	9.25
1.5"	7.5	16.5	7.68	17	9.35	21	7.4	16
2"	12.2	27	10.40	23	11.95	26	11	24
2.5"	15	33	15.00	33	19.00	42	-	-
3"	21	46	20.00	44	23.45	52	19.5	43
4"	33	73	33.00	73	36.75	81	28	62
6"	65	143	60.00	132	70	154	-	-
8"	135	297	-	-	-	-	-	-
10"	206	453	-	-	-	-	-	-
12"	322	708	-	-	-	-	-	-

PRESSURE - TEMPERATURE GRAPH

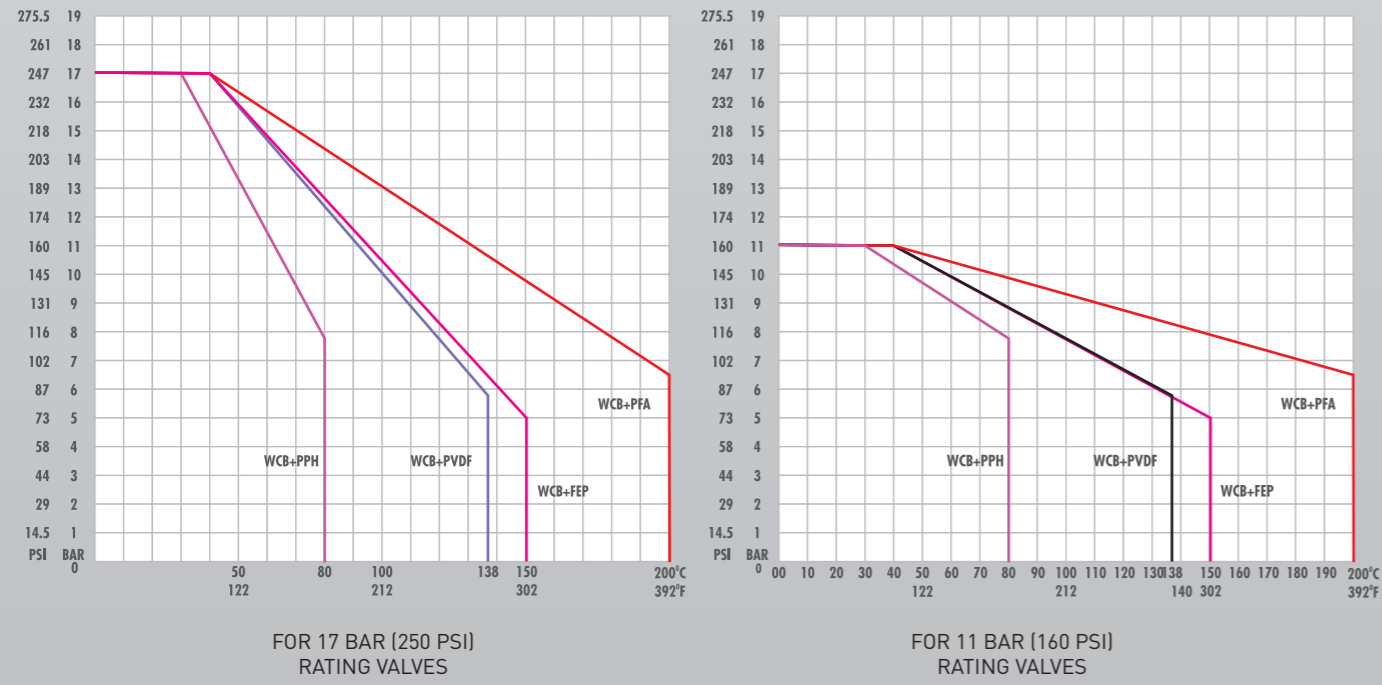

CERTIFICATION



APPROVED
ISO 15848-1
 FUGITIVE EMISSION CERTIFICATION
**PFA LINED SIDE SPLIT
 FULL PORT BALL VALVES**
 Size Range : 1/2" to 6"

APPROVED
ISO 15848-1
 FUGITIVE EMISSION CERTIFICATION
PFA LINED PLUG VALVES
 Size Range : 1/2" to 8"

APPROVED
ISO 15848-1
 FUGITIVE EMISSION CERTIFICATION
PFA LINED BUTTERFLY VALVE
 Size Range : 2" to 24"

APPROVED
DIN EN 14432:2014
PFA LINED BUTTERFLY VALVES
 Size Range : 2" to 8"

APPROVED
DIN EN 14432:2014
**PFA LINED SIDE SPLIT
 DESIGN BALL VALVES**
 Size Range : 1" to 4"

BALL VALVES - FOR CORROSIVE APPLICATIONS

AUDCO ITALIANA
Your Valve Specialist

AUDCO ITALIANA srl
Headquarter and plant

Via Carlo Dell'Acqua, 1 | 20027 Rescaldina (MI) - Italy
Tel. +39.0331.1561323 | Fax +39.0331.1561327
info@audco.it | www.audco.it