

AI - 68 SB 300RF

VALVOLA A SFERA SPLIT BODY ANSI 300 RF RB
SPLIT BODY BALL VALVE ANSI 300 RF REDUCED BORE

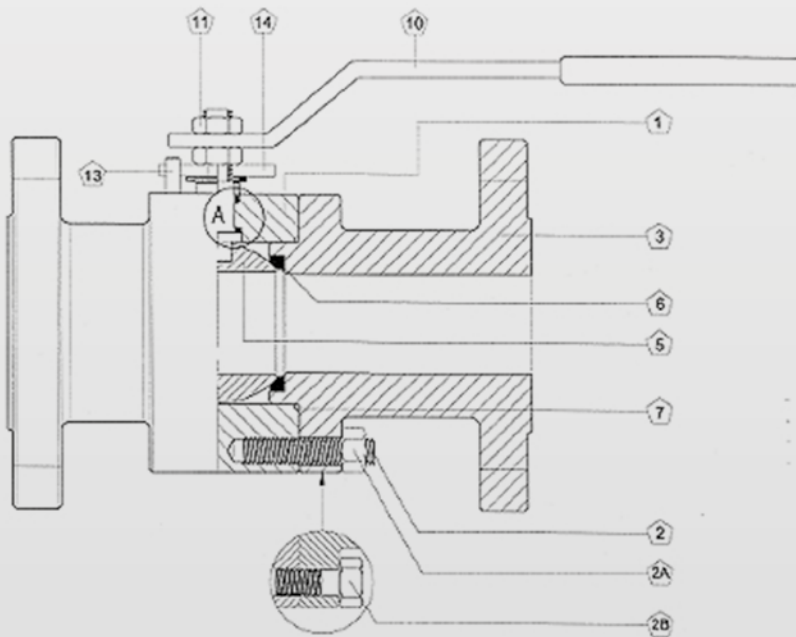

DETAIL - DETTAGLIO A

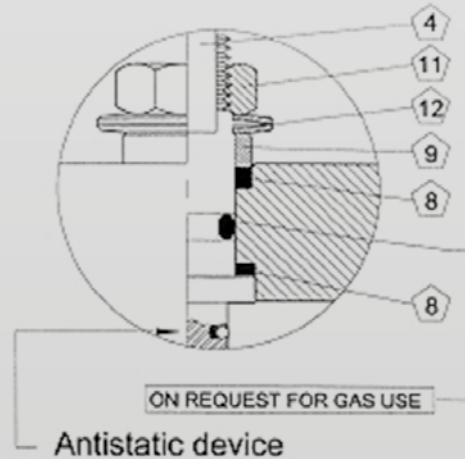

BASIC DESIGN STANDARDS

1 Body	ASTM A 105 SS. F 316
2 Bolt	Acciaio zincato *
2A Bolt	Acciaio zincato *
2B Bolt	Acciaio zincato *
3 Lateral	ASTM A 105 SS. F 316
4 Stem	SS. F 316 SS. F 316
5 Ball	SS. F 304/316 SS. F 316
6 Seat	PTFE / RPTFE PTFE / RPTFE
7 Body Seal	RPTFE RPTFE
8 Stem Seals	RPTFE RPTFE
9 Gland	Inox
10 Lever	Zinc Plated CS
11 Lever Nut	Zinc Plated CS
12 Socket Spring	Zinc Plated CS
13 Stop Pin	Zinc Plated CS
14 Stop Plate	Zinc Plated CS

* A richiesta: B7, B7M, 2H, B8, B8M

STANDARD DESCRIPTION

- Split body imbullonata flangiata ANSI #300

AUDCO ITALIANA
Your Valve Specialist

AUDCO ITALIANA srl
Headquarter and plant
Via Carlo Dell'Acqua, 1 | 20027 Rescaldina (MI) - Italy
Tel. +39.0331.1561323 | Fax +39.0331.1561327
info@audco.it | www.audco.it

AI - 68 SB 300RF

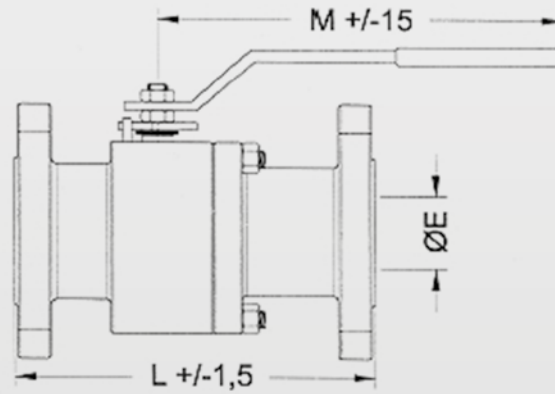

FULL BORE											
DN	15	20	25	32	40	50	65	80	100	125*	150*
NPS	1/2"	3/4"	1"	1" 1/4	1" 1/2	2"	2" 1/2	3"	4"	5"	6"
Ø E	14	19	25	32	38	48	65	76	95	119	145
L	140	152	165	180	191	216	241	283	305	381	403
M	150	185	185	280	280	280	380	380	480	480	480
Kg	4,7	5,8	7	11,3	14	20	25	40	57	72	91

3 PIECES CONSTRUCTION

- On request face to face ANSI B16.10 long pattern
- FIRE SAFE execution API 607
- ANTISTATIC design
- TA-LUFT execution / VDI 2440
- Execution for GAS Service
- Degrassing for OXYGEN service
- Lever Extension for valve insulation
- Locking Device
- Ends RTJ/FF/LG
- Execution on Customer request

MADE IN ITALY



AUDCO ITALIANA
Your Valve Specialist

AUDCO ITALIANA srl
Headquarter and plant
Via Carlo Dell'Acqua, 1 | 20027 Rescaldina (MI) - Italy
Tel. +39.0331.1561323 | Fax +39.0331.1561327
info@audco.it | www.audco.it