

FORGED GATE VALVES WELDED BONNET

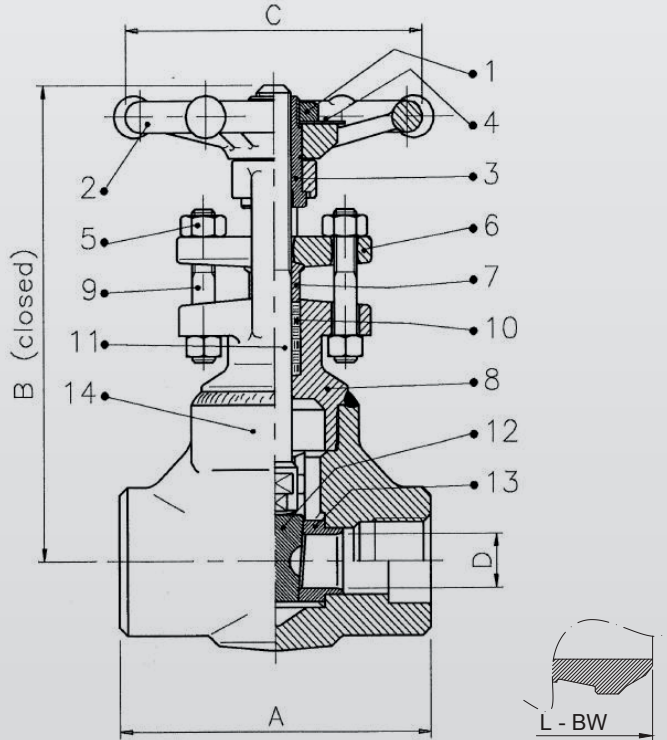

1500 Lbs

BASIC DESIGN STANDARDS

Basic Design	ISO 15761 - API 602
Wall Thickness / Pressure / Temperature	According to ANSI B16.34
Ends	SW according to ANSI B16.34 /
Dimensions	NPT-F according to ASME B1.20
Bore	Reduced (Full)

TEST PRESSURE TO API 598 bar

Class	Shell (water)	Seat (water)	Seat (air)
1500	382	280	6.0

BILL OF MATERIALS STANDARD ACCORDING TO ASTM

No	Part Name	A105/F6	F316/316
1	Handwheel Nut	Carbon Steel	A194 Gr.8
2	Handwheel	Carbon Steel	Carbon Steel + Ristan
3	Yoke Sleeve	AISI 416	AISI 416
4	Name Plate	Aluminium	INOX
5	Gland Nuts	A194 Gr.2H	A194 Gr.8
6	Gland Flange	ASTM A105	ASTM A182 F316
7	Packing Gland	A479 TP316	A479 TP316L
8	Bonnet	ASTM A105	ASTM A182 F316
9	Gland Studs	AISI 410	A193 B8M
10	Packing	Graphoil	Graphoil
11	Stem	A479 TP410	A479 TP316L
12	Wedge	A479 TP410	A479 TP316
13	Seat Rings	A479 TP410	A479 TP316
14	Body	ASTM A105N	ASTM A182 F316L

Other materials available on request

* Recommended Spare Parts

AUDCO ITALIANA
Your Valve Specialist

AUDCO ITALIANA srl
Headquarter and plant
Via Carlo Dell'Acqua, 1 | 20027 Rescaldina (MI) - Italy
Tel. +39.0331.1561323 | Fax +39.0331.1561327
info@audco.it | www.audco.it

FORGED GATE VALVES WELDED BONNET

SIZE 1500# (Reduced Bore)		DIMENSION in mm				
Inches	mm	A	B	C	D	Kg (HANDWHEEL)
1/2"	15	90	152	80	10	2.5
3/4"	20	110	180	100	14	3.8
1"	25	120	218	120	18	5.4
1-1/4"	32	130	252	140	24	8
1-1/2"	40	130	275	170	29	10.2
2"	50	150/210	320	170	36,5	15

SIZE 1500# (Full Bore)		DIMENSION in mm				
Inches	mm	A	B	C	D	Kg (HANDWHEEL)
1/4"	8	90	152	80	8	2.5
3/8"	10	90	152	80	10	2.5
1/2"	15	110	180	100	14	3.8
3/4"	20	120	218	120	18	5.4
1"	25	130	252	140	24	8
1-1/4"	32	130	275	170	29	10.2
1-1/2"	40	150/210	320	170	36.5	15
2"	50	210	325	170	40	15

ANSI CLASS 1500	PRESSURE - TEMPERATURE RATINGS TO ANSI B16.34	
Temperature	WORKING PRESSURE (bar.g) ASTM A105N (a)	
° C	A105	F316
-29 to 38	255.5	248.3
93	232.8	213.4
149	226.2	192.8
204	218.6	177.2
260	206.6	164.8
316	188.6	155.5
343	185.2	153.1
371	183.8	149.7
399	173.8	147.2
427	142.1	145.5
454	92.4	144.1
482	59.3	143.1
510	35.5	133.1
538	17.9	120.7
566	-	118.6
593	-	105.2
621	-	81.7
649	-	63.8
677	-	50.7
704	-	40.3
732	-	33.1
760	-	25.2
788	-	20.0
816	-	14.1

(a) Permissible, but not recommended for prolonged usage above 427 °C
 (b) Permissible, but not recommended for prolonged usage above 594 °C
 (c) For welding end valves only: Flanged end ratings terminate at 538°C

MADE IN ITALY



CE PED 2014/68/EU

AUDCO ITALIANA
Your Valve Specialist

AUDCO ITALIANA srl
 Headquarter and plant
 Via Carlo Dell'Acqua, 1 | 20027 Rescaldina (MI) - Italy
 Tel. +39.0331.1561323 | Fax +39.0331.1561327
 info@audco.it | www.audco.it