

CAST STEEL GATE VALVES

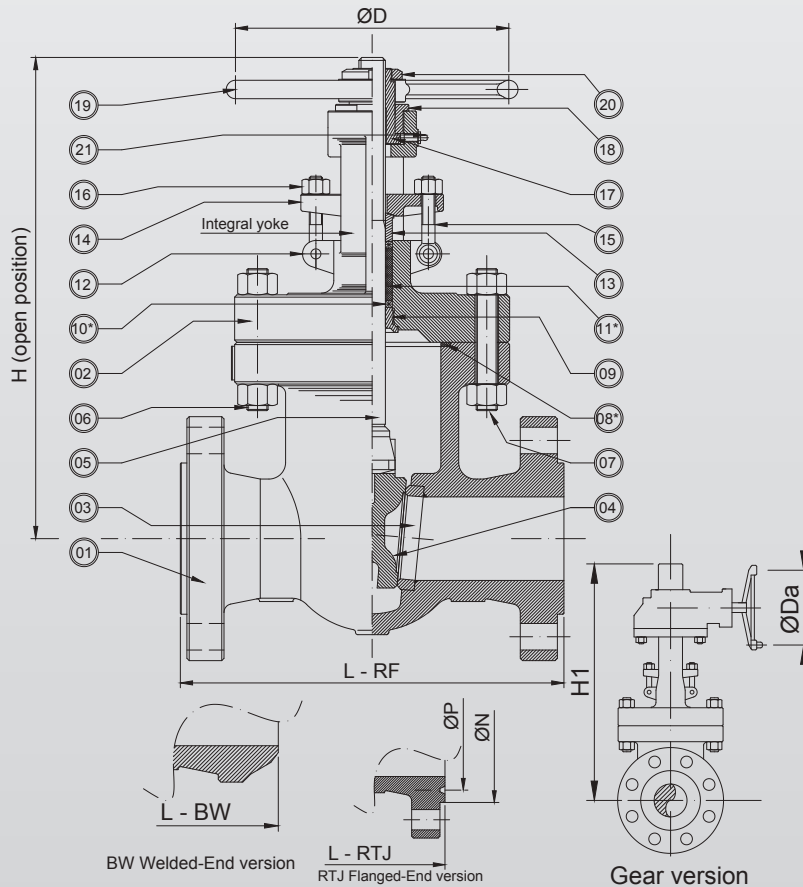

900 Lbs

BASIC DESIGN STANDARDS

Basic Design	API 600 / ANSI B16.34
Face to Face	
Dimension	ANSI B16.10
Flanges	Up to 24" ANSI B16.5 From 26" MSS SP44 ANSI B16.47 API 605
Butt-weld ends	ANSI B16.25
Testing	API 598

STANDARD DESCRIPTION

- Outside Screw & Yoke
- Bolted Bonnet with integral yoke up to Ø 6"
- Bolted Bonnet with bolted yoke from Ø 8"
- Welded Seat Ring
- Flexible Wedge from Ø 2" and greater
- Available with Gear Operator
- Special features according to Customer's requirement



TEST PRESSURE TO API 598 Psi/bar

Shell (water)	Seat (water)	Seat (air)
3370 / 232	2470 / 170	80 / 5.5

AUDCO ITALIANA
Your Valve Specialist

AUDCO ITALIANA srl
Headquarter and plant
Via Carlo Dell'Acqua, 1 | 20027 Rescaldina (MI) - Italy
Tel. +39.0331.1561323 | Fax +39.0331.1561327
info@audco.it | www.audco.it

CAST STEEL GATE VALVES

		TRIM NUMBER AS PER API 600							
No	Part Name	1	2	8	5	9	10	12	16
03	Seat Ring	410	304	STL Gr.6	STL Gr.6	MONEL	316	STL Gr.6	STL Gr.6
04	Wedge			410	STL Gr.6			STL Gr.6	
05	Stem			410	410			316	
09	Backseat			410	410			316	
	Lantern Ring			410	410			316	
13	Gland			410	410			316	

BILL OF MATERIALS STANDARD ACCORDING TO ASTM									
		Carbon Steel		Alloy Steel		Stainless Steel			
No	Part Name	WCB	LCB	WC6	C5	CF8	CF8M	CF3	CF3M
01	Body	A216 WCB	A352LCB	A217WC6	A217 C5	A351 CF8	A351 CF8M	A351 CF3	A351 CF3M
02	Bonnet	A216 WCB	A352 LCB	A217 WC6	A217 C5	A351 CF8	A351 CF8M	A351 CF3	A351 CF3M
06	Bonnet Bolts	A193-B7	A320-L7	A193-B16		A193-B8			
07	Bonnet Nuts	A194-2H	A194-4	A194-4		A194-8			
08	Body / Bonnet Gasket	304 SS + Graphite inhibited							
10-11	Stem Packing	Braided and Flexible Graphite							
12	Eyebolts Pin	A276-410							
14	Gland Flange	A216 WCB	A352 LCB	A217 WC6	A217 C5	A351 CF8	A351 CF8M	A351 CF3	A351 CF3M
15	Gland Eyebolts	A193-B7	A320-L7	A193-B16		A193-B8			
16	Gland Nuts	A194-2H	A194-4	A194-4		A194-8			
17	Stem Nut	ASTM A439-D2							
18	Retaining Nut	Carbon Steel		410					
19	Hand Wheel	Ductile Iron or Steel							
20	Hand Wheel Nut	Carbon Steel				410			
21	Grease Nipple	Stainless Steel							

SIZE		DIMENSION in mm						WEIGHT	
Inches	mm	L _(RF)	L _(BW)	H Close	H1	Ø D	Ø Da	Kg (HANDWHEEL)	Kg (GEAR OPERATOR)
2"	50	368	368	397	-	250	-	90	-
3"	80	381	381	523	-	400	-	123	-
4"	100	457	457	538	573	450	-	148	198
6"	150	610	610	759	790	500	500	420	472
8"	200	737	737	883	913	640	640	650	710

For Face-to-Face dimension L (RTJ), add +3 mm from size 2" up to 18"
add +6 mm for size 20", add +10 mm for sizes 22" and 24"

MADE IN ITALY



CE PED 2014/68/EU

AUDCO ITALIANA
Your Valve Specialist

AUDCO ITALIANA srl
Headquarter and plant
Via Carlo Dell'Acqua, 1 | 20027 Rescaldina (MI) - Italy
Tel. +39.0331.1561323 | Fax +39.0331.1561327
info@audco.it | www.audco.it