

FORGED GATE VALVES FLANGED ENDS

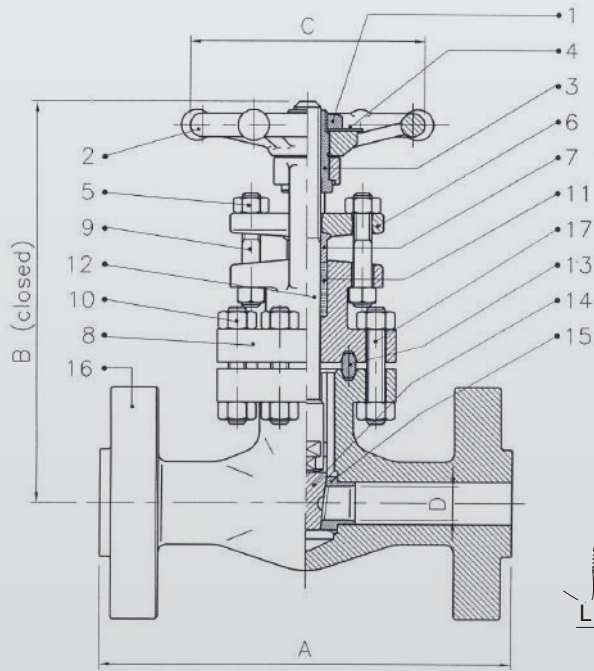

1500 Lbs

BASIC DESIGN STANDARDS

Basic Design	ISO 15761 – API 602
Wall Thickness / Pressure / Temperature	According to ANSI B16.34
Ends	SW according to ANSI B16.34 /
Dimensions	NPT-F according to ASME B1.20
Bore	Reduced & Full

TEST PRESSURE TO API 598 bar

Class	Shell (water)	Seat (water)	Seat (air)
1500	382	280	6.0

BILL OF MATERIALS STANDARD ACCORDING TO ASTM

No	Part Name	Carbon Steel	Stainless Steel
		A105/F6	SS316
01	Handwheel Nut	Carbon Steel	A194 Gr.8
02	Handwheel	Carbon Steel	Carbon St. + Rilsan
03	Yoke Sleeve	AISI 416	AISI 416
04	Name Plate	Inox	Inox
05	Gland Nut	A194 Gr. 2H	A194 Gr.8
06	Gland Flange	ASTM A105N	ASTM A316
07	Packing Gland	A479 TP316	A479 TP316L
08	Bonnet	ASTM A105N	ASTM A182 F316L
09	Gland Studs	AISI 410	A193 B8M
10	Bolts B/B	A193 B7	A193 B8
11*	Packing	Graphoil	Graphoil
12	Stem	A479 TP410	A479 TP316L
13*	Ring Joint	ASTM A182 F316	ASTM A182 F316
14	Wedge	A479 TP410	A479 TP316L
15	Seat Rings	A479 TP410	A479 TP316L
16	Body	ASTM A105N	ASTM A182 F316L
17	Studs B/B	A193 B7	A193 B8M

* Recommended Spare Parts

AUDCO ITALIANA

Your Valve Specialist

AUDCO ITALIANA srl
Headquarter and plant

Via Carlo Dell'Acqua, 1 | 20027 Rescaldina (MI) - Italy
Tel. +39.0331.1561323 | Fax +39.0331.1561327
info@audco.it | www.audco.it

FORGED GATE VALVES FLANGED ENDS

SIZE (Standard Bore)		#1500 RF - DIMENSION in mm				
Inches	mm	A	B	C	D	Kg (HANDWHEEL)
1/2"	15	216	210	100	14	10
3/4"	20	229	255	120	18	15
1"	25	254	275	140	24	17
1-1/2"	40	305	380	172	36.5	35
2"	50	368	388	260	40	55

SIZE (Standard Bore)		#2500 RF - DIMENSION in mm				
Inches	mm	A	B	C	D	Kg (HANDWHEEL)
1/2"	15	264	250	120	14	14
3/4"	20	273	255	120	14	16
1"	25	308	270	140	18	25
1-1/2"	40	384	385	260	30	50
2"	50	451	460	260	36.5	80

ANSI CLASS 1500-2500	PRESSURE - TEMPERATURE RATINGS TO ANSI B16.34			
Temperature ° C	WORKING PRESSURE (bar.g)			
	ASTM A105N (a)		ASTM A182 SS316 (c)	
	1500#	2500#	1500#	2500#
-29 to 38	255.5	425.5	248.3	413.8
93	232.8	387.9	213.4	355.9
149	226.2	377.2	192.8	321.4
204	218.6	364.1	177.2	295.2
260	206.6	344.1	164.8	274.5
316	188.6	314.5	155.5	259.3
343	185.2	308.6	153.1	255.2
371	183.8	306.2	149.7	249.7
399	173.8	289.7	147.2	245.5
427	142.1	236.6	145.5	242.8
454	92.4	153.8	144.1	240.0
482	59.3	98.6	143.1	238.6
510	35.5	59.3	133.1	222.1
538	17.9	29.7	120.7	201.0
566	-	-	118.6	197.6
593	-	-	105.2	175.5
621	-	-	81.7	135.9
649	-	-	63.8	106.6
677	-	-	50.7	84.8
704	-	-	40.3	66.9
732	-	-	33.1	55.2
760	-	-	25.2	43.4
788	-	-	20.0	33.4
816	-	-	14.1	23.8

(a) Permissible, but not recommended for prolonged usage above 427 °C
 (b) Permissible, but not recommended for prolonged usage above 594 °C
 (c) For welding end valves only: Flanged end ratings terminate at 538°C

MADE IN ITALY



AUDCO ITALIANA

Your Valve Specialist

AUDCO ITALIANA srl
 Headquarter and plant

Via Carlo Dell'Acqua, 1 | 20027 Rescaldina (MI) - Italy
 Tel. +39.0331.1561323 | Fax +39.0331.1561327
 info@audco.it | www.audco.it