

FORGED GATE VALVES FLANGED ENDS

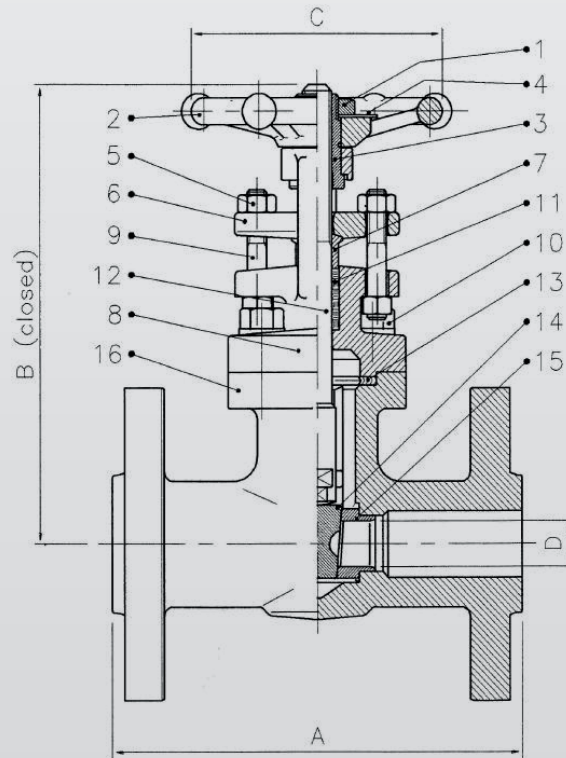

PN40 – PN100

BASIC DESIGN STANDARDS

Basic Design	DIN 3352 / 3840
Flanges	DIN 2501
Rating	DIN 2401
Face to Face	DIN 3202
Bore	Full

TEST PRESSURE TO API 598 bar

	Rating Shell (water)	Seat (water)	Seat (air)
PN40	60	48	6.0
PN100	150	120	6.0

BILL OF MATERIALS STANDARD ACCORDING TO ASTM

No	Part Name	Carbon Steel	Stainless Steel
		A105/F6	SS316
01	Handwheel Nut	Carbon Steel	A194 Gr.8
02	Handwheel	Carbon Steel	Carbon St. + Rislant
03	Yoke Sleeve	AISI 416	AISI 416
04	Name Plate	Inox	Inox
05	Gland Nut	EN 10269 (1.7709) 21CrMoV 5.7	A2-70
06	Gland Flange	ASTM A105N	X5CrNiMo17-12-2 1.4401
07	Packing Gland	A479 TP316	A479 TP316L
08	Bonnet	DIN 17243 (1.0460) C22.8 – P250GH	X5CrNiMo17-12-2 1.4401
09	Gland Studs	EN 10269 (1.7709) 21CrMoV 5.7	A2-70
10	Bolts B/B	EN 10269 (1.7709) 21CrMoV 5.7	A2-70
11*	Packing	Graphoil	Graphoil
12	Stem	EN 10088-3 (1.4021) X20Cr13	X5CrNiMo17-12-2 1.4401
13*	Gasket B/B	F316 + Graphoil	F316 + Graphoil
14	Wedge	EN 10088-3 (1.4021) X20Cr13 + ST.6	X5CrNiMo17-12-2 1.4401
15	Seat Rings	EN 10088-3 (1.4021) X20Cr13 + ST.6	X5CrNiMo17-12-2 1.4401
16	Body	DIN 17243 (1.0460) C22.8 – P250GH	X5CrNiMo17-12-2 1.4401

* Recommended Spare Parts

AUDCO ITALIANA
Your Valve Specialist

AUDCO ITALIANA srl
Headquarter and plant
Via Carlo Dell'Acqua, 1 | 20027 Rescaldina (MI) - Italy
Tel. +39.0331.1561323 | Fax +39.0331.1561327
info@audco.it | www.audco.it

FORGED GATE VALVES FLANGED ENDS

SIZE (Full Bore)		PN40 RF - DIMENSION in mm				
Inches	mm	A	B	C	D	Kg (HANDWHEEL)
1/2"	15	130	180	80	15	4.2
3/4"	20	150	188	100	20	5.5
1"	25	160	210	120	25	6.8
1-1/2"	40	240	295	140	40	14.5
2"	50	250	315	170	50	17

SIZE (Full Bore)		PN100 RF - DIMENSION in mm				
Inches	mm	A	B	C	D	Kg (HANDWHEEL)
1/2"	15	130	190	100	15	4.2
3/4"	20	150	190	100	20	5.5
1"	25	160	195	100	25	7.8
1-1/2"	40	240	248	140	40	14.5
2"	50	250	300	170	50	18

ANSI CLASS PN40 - PN100	PRESSURE - TEMPERATURE RATINGS TO ANSI B16.34			
Temperature ° C	WORKING PRESSURE (bar.g)			
	DIN 17243 (1.0460) C22.8 - P250GH (a)		X5CrNiMo17-12-2 1.4401 (c)	
	PN40	PN100	PN40	PN100
-29 to 38	39.0	102.1	37.3	99.3
93	37.2	93.1	36.4	85.5
149	34.1	90.7	33.8	77.2
204	31.7	87.6	31.3	70.7
260	28.4	82.8	29.3	65.9
316	26.0	75.5	27.6	62.1
343	23.5	74.1	25.8	61.4
371	21.9	73.4	24.9	60.0
399	21.6	69.7	24.5	59.0
427	21.1	56.9	24.0	58.3
454	-	-	23.8	57.6
482	-	-	22.6	57.2
510	-	-	21.5	53.4
538	-	-	19.7	48.3

(a) Permissible, but not recommended for prolonged usage above 427 °C
 (b) Permissible, but not recommended for prolonged usage above 594 °C
 (c) For welding end valves only: Flanged end ratings terminate at 538°C

MADE IN ITALY



AUDCO ITALIANA

Your Valve Specialist

AUDCO ITALIANA srl
 Headquarter and plant

Via Carlo Dell'Acqua, 1 | 20027 Rescaldina (MI) - Italy
 Tel. +39.0331.1561323 | Fax +39.0331.1561327
 info@audco.it | www.audco.it